

---

## 2x100GBASE-SR4 QSFP DD Optical Transceiver Module

### CAQD-MPO201-DSR4C

#### Features

- ◆ 8 channels full-duplex transceiver modules
- ◆ Transmission data rate up to 26Gbps per channel
- ◆ 8 channels 850nm VCSEL array
- ◆ 8 channels PIN photo detector array
- ◆ Internal CDR circuits on both receiver and transmitter channels
- ◆ Support CDR bypass
- ◆ Low power consumption <4W
- ◆ Hot Pluggable QSFP DD form factor
- ◆ Maximum link length of 70m on OM3 Multimode Fiber (MMF) and 100m on OM4 MMF
- ◆ MPO24 connector receptacle
- ◆ Operating case temperature 0°C to +70°C
- ◆ 3.3V power supply voltage
- ◆ RoHS2.0 compliant(lead free)



#### Applications

- ◆ IEEE 802.3bm 100GBASE SR4

#### Description

The CA OPTRONICS GROUP CAQD-MPO201-DSR4C is a Eight-Channel, Pluggable, Parallel, Fiber-Optic QSFP Double Density for 2x100 Gigabit Ethernet Applications. This transceiver is a high performance module for short-range multi-lane data communication and interconnect applications. It integrates eight data lanes in each direction with 8x25.78125Gbps bandwidth. Each lane can operate at 25.78125Gbps up to 70 m using OM3 fiber or 100 m using OM4 fiber. These modules are designed to operate over multimode fiber systems using a nominal wavelength of 850nm. The electrical interface uses a 76 contact edge type connector. The optical interface uses an 24 fiber MTP (MPO) connector. This module incorporates CA OPTRONICS GROUP proven circuit and VCSEL technology to provide reliable long life, high performance, and consistent service.

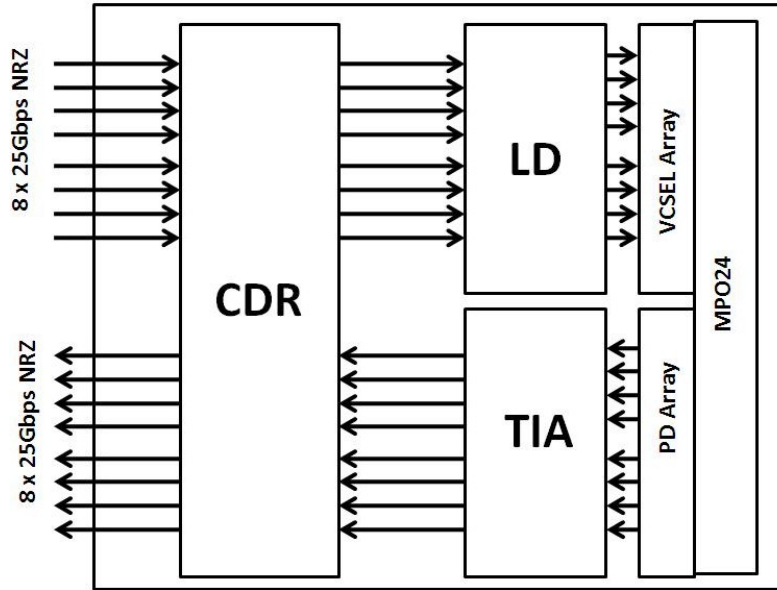

**Figure1. Module Block Diagram**

2x100GBASE-SR4 QSFP DD is one kind of parallel transceiver. VCSEL and PIN array package is key technique, through I<sup>2</sup>C system can contact with module.

**Absolute Maximum Ratings**

Parameter	Symbol	Min	Max	Unit
Supply Voltage	Vcc	-0.3	3.6	V
Input Voltage	Vin	-0.3	Vcc+0.3	V
Storage Temperature	Tst	-20	85	°C
Case Operating Temperature	Top	0	70	°C
Humidity(non-condensing)	Rh	5	95	%

### Recommended Operating Conditions

Parameter	Symbol	Min	Typical	Max	Unit
Supply Voltage	Vcc	3.13	3.3	3.47	V
Operating Case temperature	Tca	0		70	°C
Data Rate Per Lane	fd		25.78125		Gbps
Humidity	Rh	5		85	%
Power Dissipation	Pm			4	W

### Electrical Specifications

Parameter	Symbol	Min	Typical	Max	Unit
Differential input impedance	Zin	90	100	110	ohm
Differential Output impedance	Zout	90	100	110	ohm
Differential input voltage amplitude aAmplitude	$\Delta V_{in}$	300		1100	mVp-p
Differential output voltage amplitude	$\Delta V_{out}$	500		800	mVp-p
Skew	Sw			300	ps
Bit Error Rate	BER			5E-5	
Input Logic Level High	V <sub>IH</sub>	2.0		VCC	V
Input Logic Level Low	V <sub>IL</sub>	0		0.8	V
Output Logic Level High	V <sub>OH</sub>	VCC-0.5		VCC	V
Output Logic Level Low	V <sub>OL</sub>	0		0.4	V

**Note:**

1. BER=5E-5; PRBS [2^31-1@25.78125Gbps](#). Pre-FEC
2. Differential input voltage amplitude is measured between TxnP and TxnN.
3. Differential output voltage amplitude is measured between RxnP and RxnN.

## Optical Characteristics

**Table 3 - Optical Characteristics**

Parameter	Symbol	Min	Typical	Max	Unit	Notes
<b>Transmitter</b>						
Centre Wavelength	$\lambda_c$	840	850	860	nm	-
RMS spectral width	$\Delta\lambda$	-	-	0.6	nm	-
Average launch power, each lane	P <sub>out</sub>	-8.4	-	2.4	dBm	-
Optical Modulation Amplitude (OMA),each lane	OMA	-6.4		3	dBm	-
Transmitter and dispersion eye closure(TDEC),each lane	TDEC			4.3	dB	-
Extinction Ratio	ER	3	-	-	dB	-
Average launch power of OFF transmitter, each lane				-30	dB	-
Eye Mask coordinates: X1, X2, X3, Y1, Y2, Y3		SPECIFICATION VALUES {0.3,0.38,0.45,0.35,0.41,0.5}				Hit Ratio = 5x10 <sup>-5</sup>
<b>Receiver</b>						
Centre Wavelength	$\lambda_c$	840	850	860	nm	-
Stressed receiver sensitivity in OMA				-5.2	dBm	1
Maximum Average power at receiver , each lane input, each lane				2.4	dBm	-
Minimum Average power at receiver , each lane				-10.3	dBm	-
Receiver Reflectance				-12	dB	-
LOS Assert		-30			dBm	-
LOS De-Assert – OMA				-7.5	dBm	-
LOS Hysteresis		0.5			dB	-

**Note:**

1. Measured with conformance test signal at TP3 for BER = 5E-5 Per-FEC

## Pin Description

**Table 1- Pad Function Definition**

Pad	Logic	Symbol	Description	Plug Sequence <sup>4</sup>	Notes
1		GND	Ground	1B	1
2	CML-I	Tx2n	Transmitter Inverted Data Input	3B	
3	CML-I	Tx2p	Transmitter Non-Inverted Data Input	3B	
4		GND	Ground	1B	1
5	CML-I	Tx4n	Transmitter Inverted Data Input	3B	
6	CML-I	Tx4p	Transmitter Non-Inverted Data Input	3B	
7		GND	Ground	1B	1
8	LVTTL-I	ModSelL	Module Select	3B	
9	LVTTL-I	ResetL	Module Reset	3B	
10		VccRx	+3.3V Power Supply Receiver	2B	2
11	LVC MOS-I/O	SCL	2-wire serial interface clock	3B	
12	LVC MOS-I/O	SDA	2-wire serial interface data	3B	
13		GND	Ground	1B	1
14	CML-O	Rx3p	Receiver Non-Inverted Data Output	3B	
15	CML-O	Rx3n	Receiver Inverted Data Output	3B	
16		GND	Ground	1B	1
17	CML-O	Rx1p	Receiver Non-Inverted Data Output	3B	
18	CML-O	Rx1n	Receiver Inverted Data Output	3B	
19		GND	Ground	1B	1
20		GND	Ground	1B	1
21	CML-O	Rx2n	Receiver Inverted Data Output	3B	
22	CML-O	Rx2p	Receiver Non-Inverted Data Output	3B	
23		GND	Ground	1B	1
24	CML-O	Rx4n	Receiver Inverted Data Output	3B	
25	CML-O	Rx4p	Receiver Non-Inverted Data Output	3B	
26		GND	Ground	1B	1
27	LVTTL-O	ModPrsL	Module Present	3B	
28	LVTTL-O	IntL	Interrupt	3B	
29		VccTx	+3.3V Power supply transmitter	2B	2
30		Vcc1	+3.3V Power supply	2B	2
31	LVTTL-I	InitMode	Initialization mode; In legacy QSFP applications, the InitMode pad is called LPMODE	3B	
32		GND	Ground	1B	1
33	CML-I	Tx3p	Transmitter Non-Inverted Data Input	3B	
34	CML-I	Tx3n	Transmitter Inverted Data Input	3B	
35		GND	Ground	1B	1
36	CML-I	Tx1p	Transmitter Non-Inverted Data Input	3B	
37	CML-I	Tx1n	Transmitter Inverted Data Input	3B	
38		GND	Ground	1B	1

Pad	Logic	Symbol	Description	Plug Sequence <sup>4</sup>	Notes
39		GND	Ground	1A	1
40	CML-I	Tx6n	Transmitter Inverted Data Input	3A	
41	CML-I	Tx6p	Transmitter Non-Inverted Data Input	3A	
42		GND	Ground	1A	1
43	CML-I	Tx8n	Transmitter Inverted Data Input	3A	
44	CML-I	Tx8p	Transmitter Non-Inverted Data Input	3A	
45		GND	Ground	1A	1
46		Reserved	For future use	3A	3
47		VS1	Module Vendor Specific 1	3A	3
48		VccRx1	3.3V Power Supply	2A	2
49		VS2	Module Vendor Specific 2	3A	3
50		VS3	Module Vendor Specific 3	3A	3
51		GND	Ground	1A	1
52	CML-O	Rx7p	Receiver Non-Inverted Data Output	3A	
53	CML-O	Rx7n	Receiver Inverted Data Output	3A	
54		GND	Ground	1A	1
55	CML-O	Rx5p	Receiver Non-Inverted Data Output	3A	
56	CML-O	Rx5n	Receiver Inverted Data Output	3A	
57		GND	Ground	1A	1
58		GND	Ground	1A	1
59	CML-O	Rx6n	Receiver Inverted Data Output	3A	
60	CML-O	Rx6p	Receiver Non-Inverted Data Output	3A	
61		GND	Ground	1A	1
62	CML-O	Rx8n	Receiver Inverted Data Output	3A	
63	CML-O	Rx8p	Receiver Non-Inverted Data Output	3A	
64		GND	Ground	1A	1
65		NC	No Connect	3A	3
66		Reserved	For future use	3A	3
67		VccTx1	3.3V Power Supply	2A	2
68		Vcc2	3.3V Power Supply	2A	2
69		Reserved	For Future Use	3A	3
70		GND	Ground	1A	1
71	CML-I	Tx7p	Transmitter Non-Inverted Data Input	3A	
72	CML-I	Tx7n	Transmitter Inverted Data Input	3A	
73		GND	Ground	1A	1
74	CML-I	Tx5p	Transmitter Non-Inverted Data Input	3A	
75	CML-I	Tx5n	Transmitter Inverted Data Input	3A	
76		GND	Ground	1A	1
Note 1: QSFP-DD uses common ground (GND) for all signals and supply (power). All are common within the QSFP-DD module and all module voltages are referenced to this potential unless otherwise noted. Connect these directly to the host board signal-common ground plane.					
Note 2: VccRx, VccRx1, Vcc1, Vcc2, VccTx and VccTx1 shall be applied concurrently. Requirements defined for the host side of the Host Card Edge Connector are listed in Table 4. VccRx, VccRx1, Vcc1, Vcc2, VccTx and VccTx1 may be internally connected within the module in any combination. The connector Vcc pins are each rated for a maximum current of 1000 mA.					
Note 3: All Vendor Specific, Reserved and No Connect pins may be terminated with 50 ohms to ground on the host. Pad 65 (No Connect) shall be left unconnected within the module. Vendor specific and Reserved pads shall have an impedance to GND that is greater than 10 kOhms and less than 100 pF.					
Note 4: Plug Sequence specifies the mating sequence of the host connector and module. The sequence is 1A, 2A, 3A, 1B, 2B, 3B. (see Figure 2 for pad locations) Contact sequence A will make, then break contact with additional QSFP-DD pads. Sequence 1A, 1B will then occur simultaneously, followed by 2A, 2B, followed by 3A, 3B.					

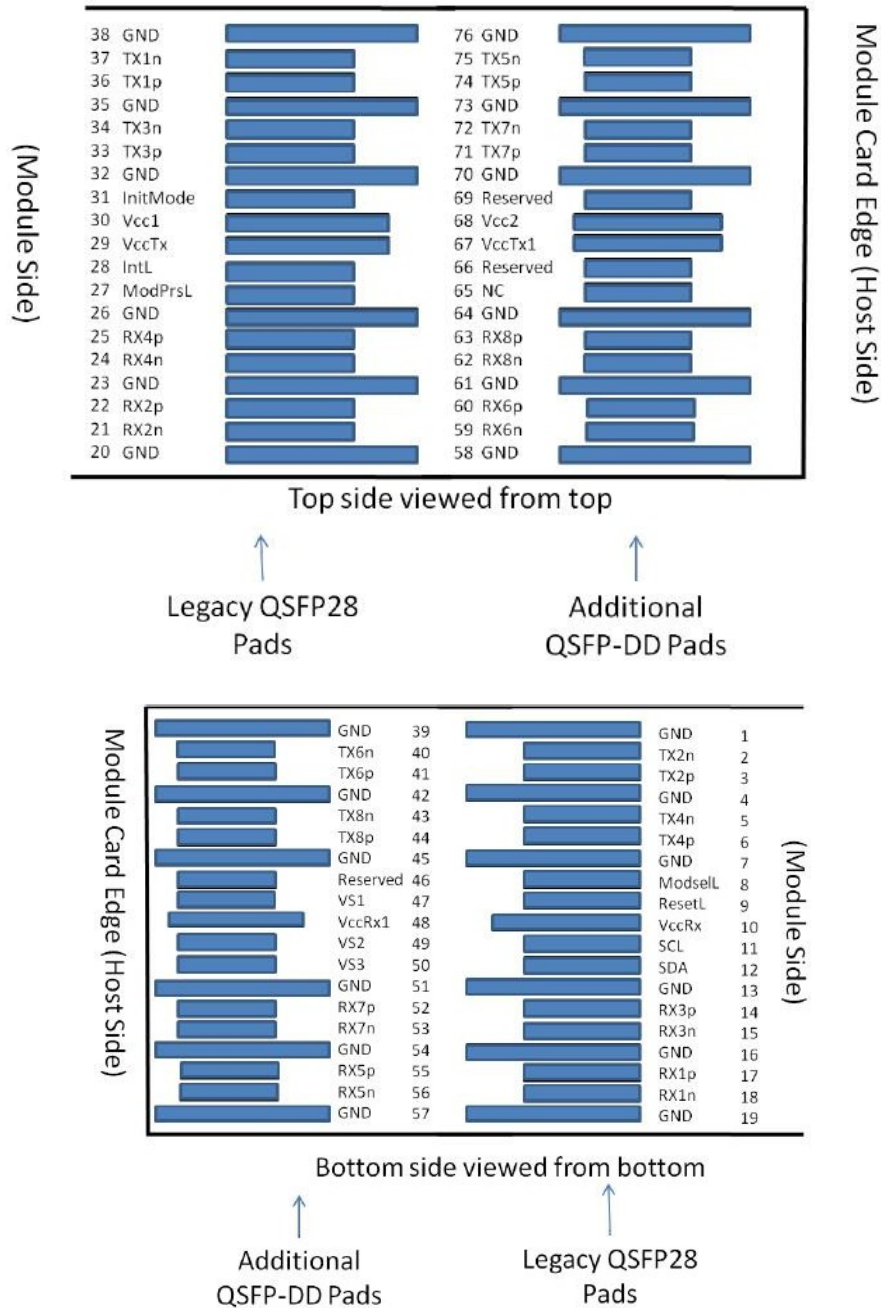

**Figure2. Electrical Pin-out Details**

**ModSelL Pin**

The ModSelL is an input signal that must be pulled to Vcc in the QSFP-DD module. When held low by the host, the module responds to 2-wire serial communication commands. The ModSelL allows the use of multiple QSFP-DD modules on a single 2-wire interface bus. When ModSelL is “High”, the module shall not respond to or acknowledge any 2-wire interface communication from the host.

In order to avoid conflicts, the host system shall not attempt 2-wire interface communications within the ModSelL de-assert time after any QSFP-DD modules are deselected. Similarly, the host must wait at least for the period of the ModSelL assert time before communicating with the newly selected module. The assertion and de-asserting periods of different modules may overlap as long as the above timing requirements are met.

#### **ResetL Pin**

The ResetL signal shall be pulled to Vcc in the module. A low level on the ResetL signal for longer than the minimum pulse length ( $t_{\text{Reset\_init}}$ ) (See Table 13 ) initiates a complete module reset, returning all user module settings to their default state.

#### **InitMode Pin**

InitMode is an input signal. The InitMode signal must be pulled up to Vcc in the QSFP-DD module. The InitMode signal allows the host to define whether the QSFP-DD module will initialize under host software control (InitMode asserted High) or module hardware control (InitMode deasserted Low). Under host software control, the module shall remain in Low Power Mode until software enables the transition to High Power Mode, as defined in Section 7.5. Under hardware control (InitMode de-asserted Low), the module may immediately transition to High Power Mode after the management interface is initialized. The host shall not change the state of this signal while the module is present. In legacy QSFP applications, this signal is named LPMMode. See SFF-8679 for signal description.

#### **ModPrsL Pin**

ModPrsL must be pulled up to Vcc Host on the host board and grounded in the module. The ModPrsL is asserted “Low” when the module is inserted and deasserted “High” when the module is physically absent from the host connector.

#### **IntL Pin**

IntL is an output signal. The IntL signal is an open collector output and must be pulled to Vcc Host on the host board. When the IntL signal is asserted Low it indicates a change in module state, a possible module operational fault or a status critical to the host system. The host identifies the source of the interrupt using the 2-wire serial interface. The IntL signal is deasserted “High” after all set interrupt flags are read.



## Power Supply Filtering

The host board should use the power supply filtering shown in Figure3.

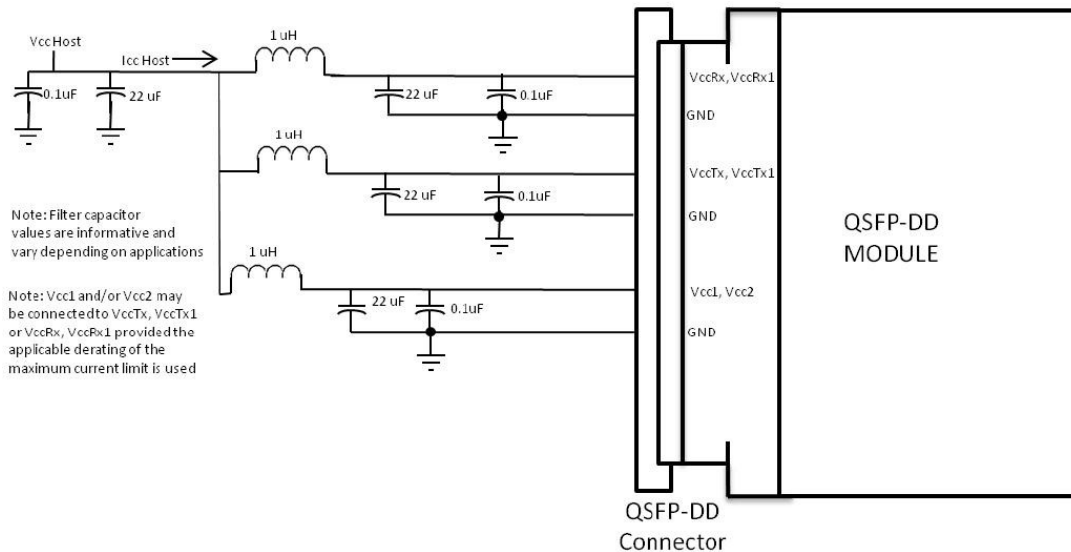

**Figure3. Host Board Power Supply Filtering**

## Optical Interface Lanes and Assignment

The optical interface port is a male MPO24 connector .

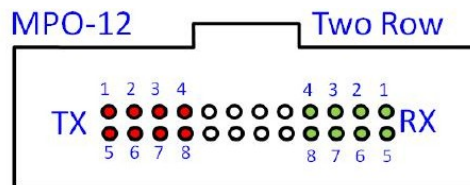

**Figure 4. Optical Receptacle and Channel Orientation**

## DIAGNOSTIC MONITORING INTERFACE(OPTIONAL)

Digital diagnostics monitoring function is available on all CA OPTRONICS GROUP QSFP DD products. A 2-wire serial interface provides user to contact with module.

The structure of the memory is shown in Figure 5. The memory space is arranged into a lower, single page, address space of 128 bytes and multiple upper address space pages. This structure permits timely access to addresses in the lower page, e.g. Interrupt Flags and Monitors. Less time critical entries, e.g. serial ID information and threshold settings, are available with the Page Select function. The structure also provides address expansion by adding additional upper pages as needed.

The interface address used is A0xh and is mainly used for time critical data like interrupt handling in order to enable a one-time-read for all data related to an interrupt situation. After an interrupt, IntL, has been asserted, the host can read out the flag field to determine the affected channel and type of flag.

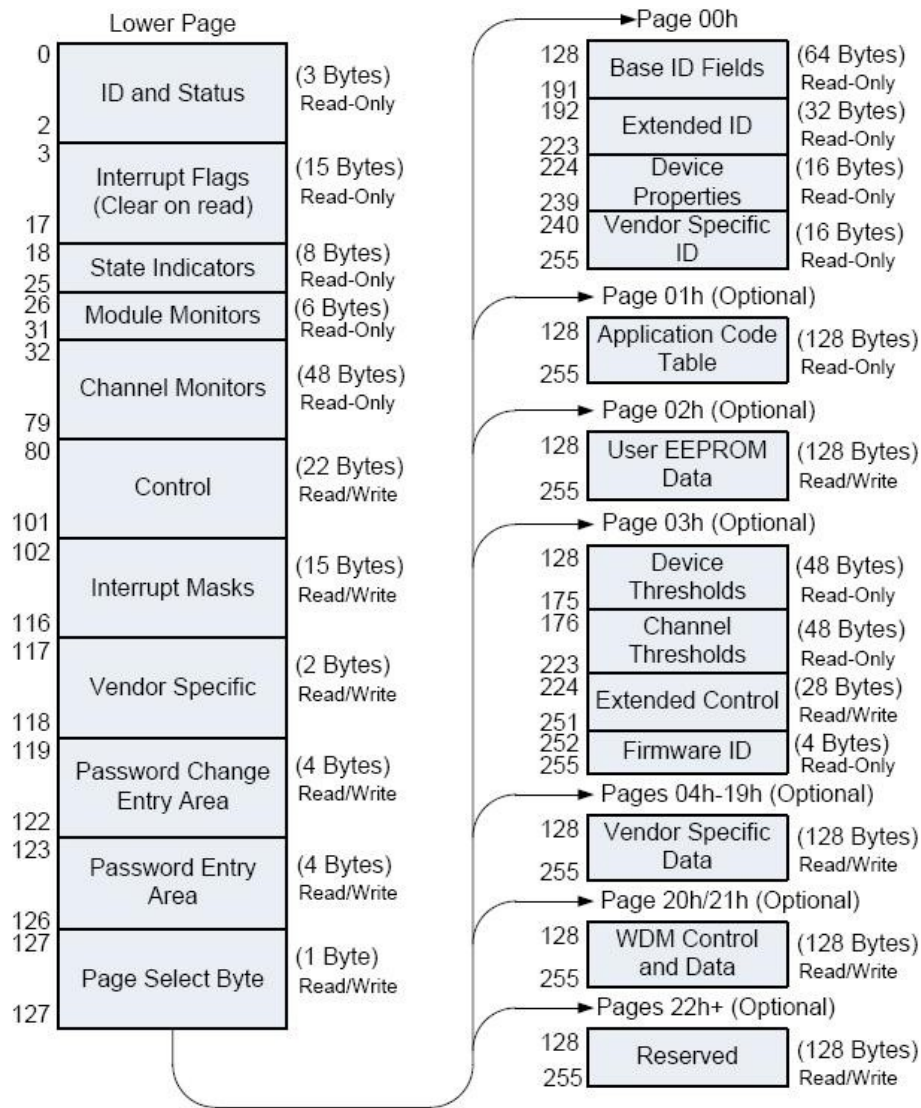

**Figure 5. QSFP DD Memory Map**

**Table 16- Lower Page Overview (Lower Page)**

Address	Description	Type
0 - 2	Id and Status (3 bytes)	Read-only
3 - 17	Interrupt Flags (15 bytes)	Read-only
18 - 25	State Indicators (8 bytes)	Read-only
26 - 31	Module card Monitors (6 bytes)	Read-only
32 - 79	Channel Monitors (48 bytes)	Read-only
80 - 101	Control Fields (22 bytes)	Read/Write
102 - 116	Interrupt Flag Masks (15 bytes)	Read/Write
117 - 118	Reserved	Read/Write
119 - 122	Password Change Area (4 bytes)	Write-Only
123 - 126	Password Entry Area (4 bytes)	Write-Only
127	Page Select Byte	Read/Write

**Figure6. Low Memory Map**

**Table 28- Upper Page 0 Overview (Page 00h)**

Address	Size (bytes)	Name	Description
<b>Base ID Fields:</b>			
128	1	Identifier	Identifier Type of module
129	1	Ext. Identifier	Extended Identifier
130	1	Connector Type	Code for media connector type
131-138	8	Specification compliance	Code for electronic compatibility or optical compatibility
139	1	Encoding	Code for serial encoding algorithm
140	1	BR, nominal	Nominal bit rate, units of 100 Mbits/s
141	1	Extended rate select compliance	Tags for extended rate select compliance
142-146	5	Link length	Link length / transmission media
147	1	Device technology	Device technology
148-163	16	Vendor name	Vendor name (ASCII)
164	1	Extended Module	Extended Module codes for InfiniBand
165-167	3	Vendor OUI	Vendor IEEE company ID
168-183	16	Vendor PN	Part number provided by vendor (ASCII)
184-185	2	Vendor rev	Revision level for part number provided by vendor (ASCII)
186-187	2	Wavelength or Copper	Nominal laser wavelength

		cable Attenuation	(wavelength=value/20 in nm) or copper cable attenuation in dB at 2.5GHz (Adrs 186) and 5.0GHz (Adrs 187)
188-189	2	Wavelength tolerance	Guaranteed range of laser wavelength(+/- value) from nominal wavelength.(wavelength Tolerance=value/200 in nm)
190	1	Max case temp.	Maximum case temperature in degrees C
191	1	CC_BASE	Check code for base ID fields (addresses 128-190 inclusive)
Extended ID Fields:			
192-195	4	Options	Indicates which optional capabilities are implemented in the module
196-211	16	Vendor S/N	Vendor product serial number
212-219	8	Date Code	Vendor's manufacturing date code
220	1	Diagnostic Monitoring Type	Indicates which types of diagnostic monitoring are implemented in the module
221-222	2	Enhanced Options	Indicates which optional enhanced features are implemented in the module.
223	1	CC_EXT	Check code for the Extended ID Fields (addresses 192-222 inclusive)
224-238	15	Device Properties	Provides detailed information about the device
239	1	CC-PROP	Check code for the Device Properties Fields (addresses 224-238 inclusive)
Vendor Specific ID Fields:			
240-255	16	Vendor-Specific	Vendor-specific ID information

Figure7. Page 00 Memory Map

### Timing for Soft Control and Status Functions

Table 13- Timing for QSFP-DD soft control and status functions

Parameter	Symbol	Min	Max	Unit	Conditions
MgmtInitDuration	Max MgmtInit Duration		2000	ms	Time from power on <sup>2</sup> , hot plug or rising edge of reset until completion of the MgmtInit State
ResetL Assert Time	t_reset_init	2		us	Minimum pulse time on the ResetL signal to initiate a module reset.
IntL Assert Time	ton_IntL		200	ms	Time from occurrence of condition triggering IntL until Vout:IntL=Vol
IntL Deassert Time	toff_IntL		500	us	Time from clear on read <sup>3</sup> operation of associated flag until Vout:IntL=Voh. This includes deassert times for Rx LOS, Tx Fault and other flag bits.
Rx LOS Assert Time	ton_los		100	ms	Time from Rx LOS state to Rx LOS bit set (value = 1b) and IntL asserted.
Rx LOS Assert Time (optional fast mode)	ton_losf		1	ms	Time from Rx LOS state to Rx LOS bit set (value = 1b) and IntL asserted.
Rx LOS Deassert Time (optional fast mode)	toff_losf	3		ms	Time from signal present to negation of Rx LOS status bit.
Tx Fault Assert Time	ton_Txfault		200	ms	Time from Tx Fault state to Tx Fault bit set (value=1b) and IntL asserted.
Flag Assert Time	ton_flag		200	ms	Time from occurrence of condition triggering flag to associated flag bit set (value=1b) and IntL asserted.
Mask Assert Time	ton_mask		100	ms	Time from mask bit set (value=1b) <sup>1</sup> until associated IntL assertion is inhibited
Mask Deassert Time	toff_mask		100	ms	Time from mask bit cleared (value=0b) <sup>1</sup> until associated IntL operation resumes
Application or Rate Select Change Time	t_ratesel		100	ms	Time from change of state of Application or Rate Select bit <sup>1</sup> until transmitter or receiver bandwidth is in conformance with appropriate specification
Note 1. Measured from the rising edge of SDA in the stop bit of the write transaction					
Note 2. Power on is defined as the instant when supply voltages reach and remain at or above the minimum level specified in Table 6.					
Note 3. Measured from the rising edge of SDA in the stop bit of the read transaction					

Figure9. Timing Specification

## Mechanical Dimensions

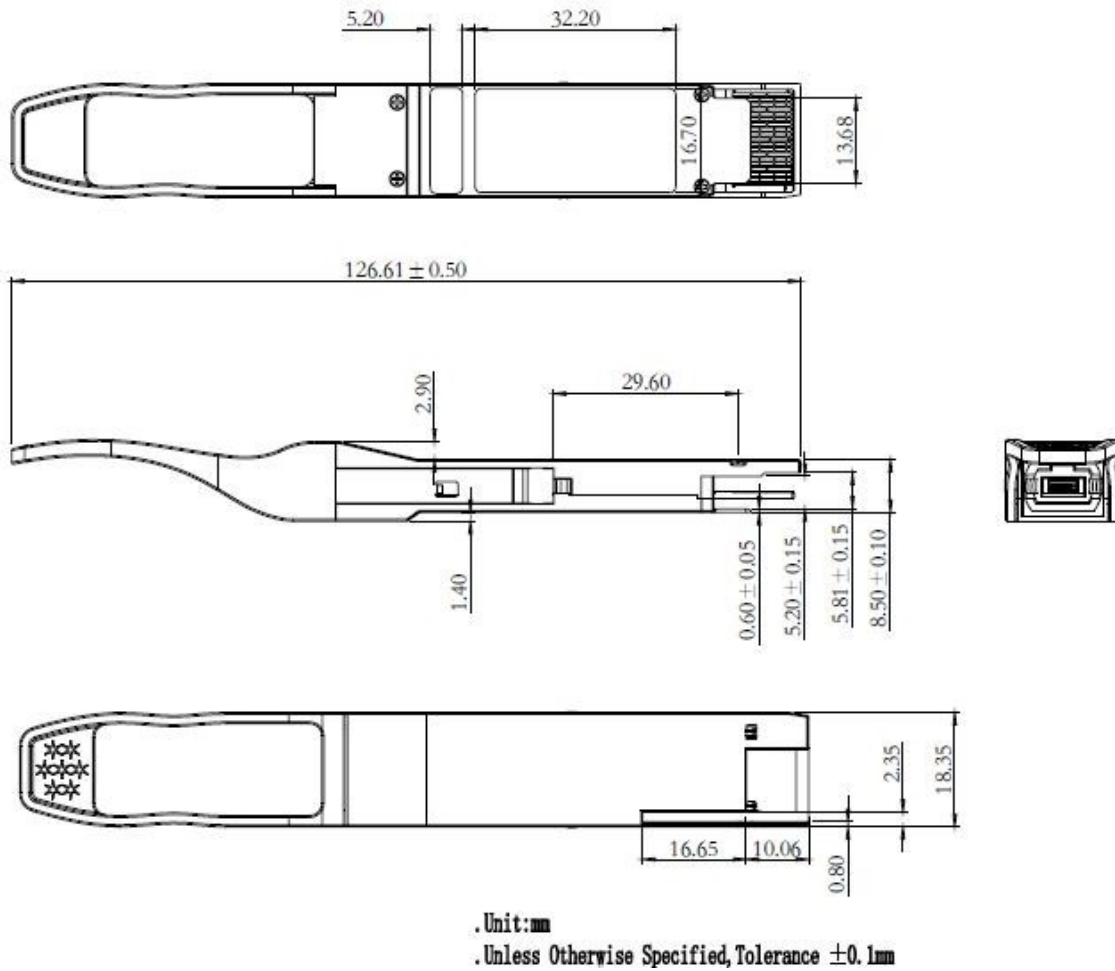

**Figure10. Mechanical Specifications**

## Regulatory Compliance

CA OPTRONICS GROUP CADM-SPO201-LR8C are Class 1 Laser Products. They are compliant with the following standards:

Feature	Standard
Laser Safety	IEC 60825-1:2014 (3 <sup>rd</sup> Edition) IEC 60825-2:2004/AMD2:2010 EN 60825-1:2014 EN 60825-2:2004+A1+A2
Electrical Safety	EN 62368-1: 2014 IEC 62368-1:2014 UL 62368-1:2014
Environmental protection	Directive 2011/65/EU with amendment(EU)2015/863

Feature	Standard
CE EMC	EN55032: 2015 EN55035: 2017 EN61000-3-2:2014 EN61000-3-3:2013
FCC	FCC Part 15, Subpart B ANSI C63.4-2014

Complies with FDA performance standards for laser products except for deviations pursuant to Laser Notice No. 50, dated June 24, 2007.

### References

1. QSFP-DD Hardware Rev 5.0
2. CMIS V4.0
3. Ethernet 100GBASE-SR4 IEEE802.3bm

### Ordering information

Part Number	Product Description
CAQD-MPO201-DSR4C	QSFP DD, 2x100GBASE-SR4, 70m on OM3 Multimode Fiber (MMF)and 100m on OM4 MMF

### Important Notice

Performance figures, data and any illustrative material provided in this data sheet are typical and must be specifically confirmed in writing by CA OPTRONICS GROUP before they become applicable to any particular order or contract. In accordance with the CA OPTRONICS GROUP policy of continuous improvement specifications may change without notice.

The publication of information in this data sheet does not imply freedom from patent or other protective rights of CA OPTRONICS GROUP or others. Further details are available from any CA OPTRONICS GROUP sales representative.

[sales@caoptronicsgroup.com](mailto:sales@caoptronicsgroup.com)

<http://www.caoptronicsgroup.com>

